



Lysaght Flatdek® II

Roof cladding for home improvements

LYSAGHT FLATDEK II is a long-span cladding, particularly well suited to many types of home improvement projects like room additions, carports and awnings.

The underside of FLATDEK II features clean uninterrupted lines, with an attractive gloss finish. Fixing methods are easy and save time.

Simple fixing

The unique overlapping dovetail ribs of the FLATDEK II profile can be easily fitted together by hand.

FLATDEK II is simply and economically fixed on top of its supporting members using self-drilling screws in the pans. This method, using the recommended fasteners, is appropriate for open sided awnings where a high degree of weather tightness is not

required. Greater weather tightness can be achieved using bonded washers (see table on Page 2).

Minimum roof pitch

FLATDEK II may be used on pitches from as low as 2° (1 in 30).

Insist on BlueScope Lysaght

When you specify BlueScope Lysaght products you have the added advantage of dealing with a company whose expertise and experience with steel stretches back for well over a century, as well as a company with a reputation for consistently producing top quality products.



Home Improvements



Structural Products



Rainwater Products



Fencing Products



Roofing & Walling Products



House Framing Products



Customer Support

Lysaght Flatdek® II

Material specifications

FLATDEK II is made from:

- ZINCALUME® steel complying with AS 1397—2001 G550, AZ150 (550 MPa minimum yield stress, 150 g/m² minimum coating mass);

The base metal thickness is 0.42mm.

The COLORBOND® prepainted steel complies with AS/NZS 2728:1997.

Lengths

Sheets are custom cut to length.

Limit states wind pressures

FLATDEK II offers the full benefits of the latest methods for modelling wind pressures. The wind pressure capacity table is based on full scale tests conducted at BlueScope Lysaght's NATA-registered testing laboratory, using the direct pressure-testing rig.

Testing was conducted in accordance with AS1562.1—1992 Design and installation of sheet roof and wall cladding—Metal, and AS4040.2—1992 Resistance to wind pressure for non-cyclone regions.

FLATDEK II limit state wind pressure capacities (kPa)

Type of span	Limit state	Span (mm)												
		1500	1800	2100	2400	2700	3000	3300	3600	3900	4200	4500	4800	5100
SINGLE	Serviceability	0.98	0.80	0.63	0.50	0.40	0.34	0.30	0.28	0.25	0.23	0.21	0.20	0.18
	Strength*	7.30	6.65	6.00	5.35	4.70	4.10	3.50	3.05	2.65	2.35	2.10	1.85	1.65
END	Serviceability	1.25	1.08	0.93	0.80	0.69	0.60	0.53	0.48	0.43	0.38	0.34	0.31	—
	Strength*	6.15	5.75	5.30	4.80	4.30	3.80	3.30	2.85	2.55	2.30	2.10	1.95	—
INTERNAL	Serviceability	1.30	1.16	1.04	0.963	0.83	0.75	0.68	0.63	0.57	0.52	0.47	0.43	—
	Strength*	6.75	6.10	5.50	5.00	4.55	4.15	3.85	3.50	3.20	2.90	2.60	2.30	—

* A capacity reduction factor of $\phi = 0.9$ has been applied to strength capacities. Table values are based on supports of 1 mm BMT.

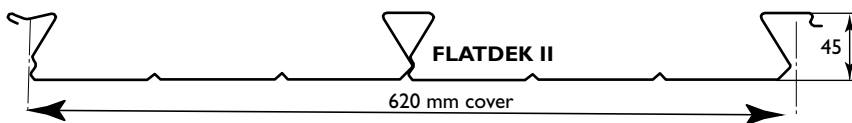

Fastener locations

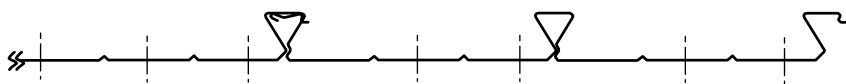

Supports: 2 fasteners per sheet

* Extra fastener for edge sheet with V-top ridge

Fasteners

	Fixing to steel up to 0.75 mm BMT	Fixing to steel 0.75 to 3 mm BMT	Fixing to timber
Standard fixing	Self drilling, self tapping screws with hex. washer-head & EPDM washer 10-12 x 20 mm	Self drilling, self tapping screws with hex. washer-head & EPDM washer 10-16 x 16 mm	Type 17 screws, with hex. washer-head & EPDM washer SOFTWOOD: 10-12 x 30 mm HARDWOOD: 10-12 x 20 mm
Higher weather tightness	Self drilling, self tapping screws with hex. washer-head & 16 mm x 0.9 mm aluminium/EPDM bonded washer 12-11 x 25 mm	Self drilling, self tapping screws with hex. washer-head & 16 mm x 0.9 mm aluminium/EPDM bonded washer 12-14 x 20 mm	Type 17 screws, with hex. washer-head & 16 mm x 0.9 mm aluminium/EPDM bonded washer SOFTWOOD & HARDWOOD: 12-11 x 40 mm

When fixing to FRMLOK, tighten until washer is just gripped enough to give a weathertight seal. Don't tighten any more.

Maximum support spacings

The maximum recommended support spacings are based on testing in accordance with AS1562.1—1992, AS4040.1—1992 and AS4040.2—1992.

Depending on support spacings used, FLATDEK II can be installed as either a

- light foot traffic roof (incidental maintenance foot traffic acceptable); this considers both resistance to wind pressure and light foot traffic, or
- no foot traffic roof (will not support the weight of a person walking on it), this considers resistance to wind pressure only.

The pressure considered is based on a typical awning $C_{pn} = -0.8$ and $KI = 1.5$ adjacent to an enclosed structure.

The tables are based on FLATDEK II fixed to supports of 1.0mm BMT minimum. For FLATDEK II awnings applications, the awning span is often governed by the capacity of the receiver channel and its connections. This must be considered in the design of any awning system.

Maximum support spacings (mm)

Type of span	Wind classification to AS 4055 & BCA			
	N1 (W28)	N2 (W33)	N3 (W41N)	N4 (W50N)
Spans for light foot traffic				
Single	2400	2400	2400	2400
End	2800	2800	2800	2800
Internal	3200	3200	3200	3200
Spans for no foot traffic				
Single	5100*	5100*	4500	3300
End	4800	4800	3700	3000
Internal	4800	4800	4450	3500
Stiffened overhangs	600	600	450	400

Supports must be not less than 1 mm BMT.

* Spans of 5100mm may result in noticeable deflections under maximum loads. When deflections need to be considered in designs, reduce these spans to 4800 mm.

Non-cyclonic areas

The information in this brochure is suitable for use only in areas where a tropical cyclone is unlikely to occur as defined in AS 1170.2—2002 SAA Loading Code, Part 2: Wind Loads.

Ask for advice from our information service on designs to be used in cyclonic areas.

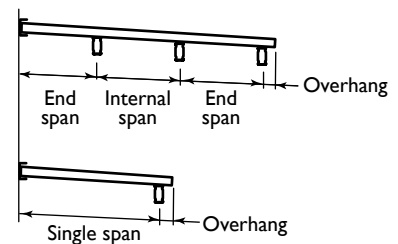

Sections

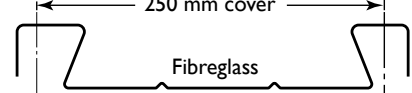

Installation of a typical awning

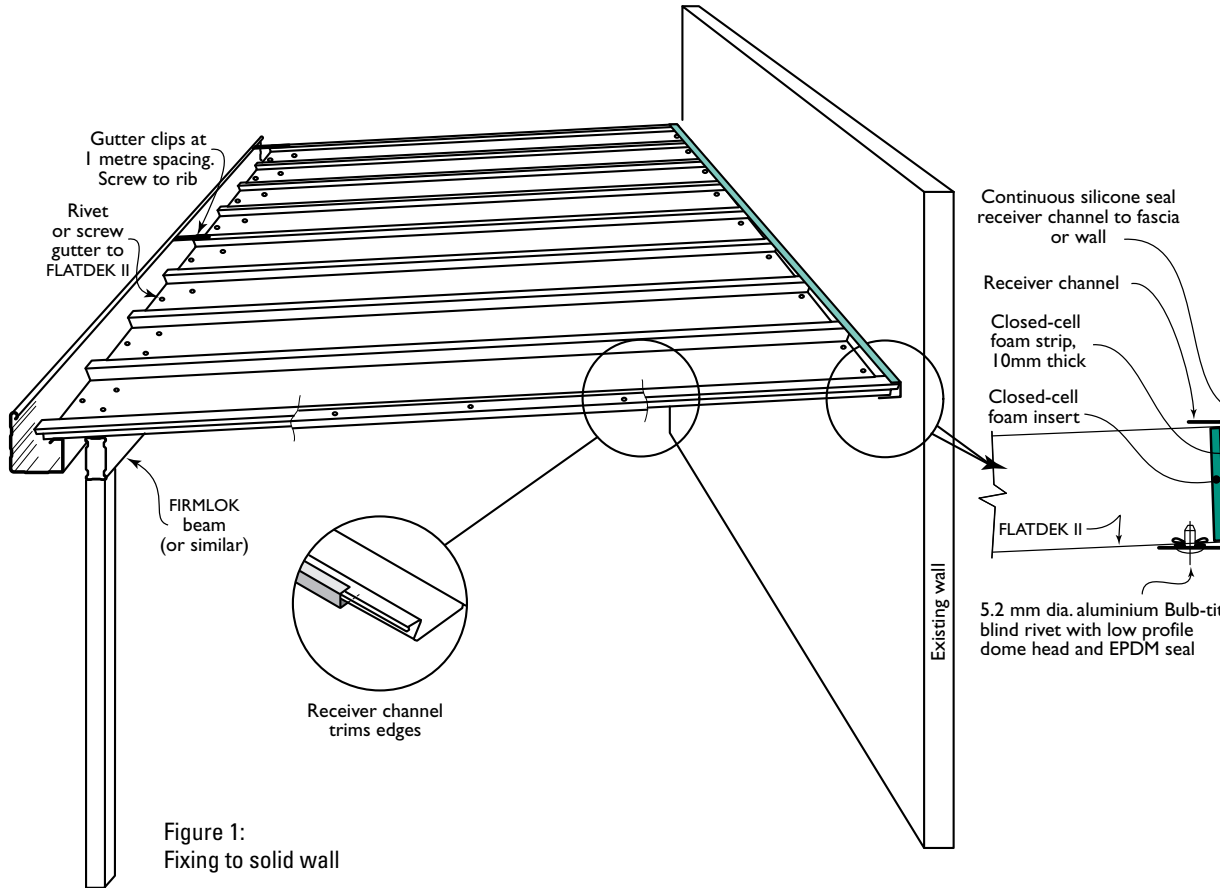

Figure 1:
Fixing to solid wall

A receiver channel is usually used to securely fix the FLATDEK II roof to the main building—usually to the building fascia, but the channel can be fixed to a solid wall if there is sufficient height (Figure 1).

Laying FLATDEK II: Introduction

Laying of FLATDEK II is easy. Lay sheets towards the prevailing wind.

Before you join sheets, it is important to remove the protective plastic coating otherwise the sheets won't clip together properly. Be careful to place the sheets on a soft surface to prevent scratching.

Some people find it easier to join two sheets together on the ground before placing them on the structure.

Laying FLATDEK II: Procedure

Insert the closed-cell foam strip into the receiver channel.

Push the first sheet firmly into the receiver channel, with the flat-topped rib to the edge of the roof (Figure 2).

- Fix the sheet at the beam end as shown in diagram above. Tighten screws until washer is just gripped enough to give a weathertight seal. Don't tighten any more.

- Squeeze a closed-cell foam insert into the receiver channel and massage it to fit neatly all round (As illustrated

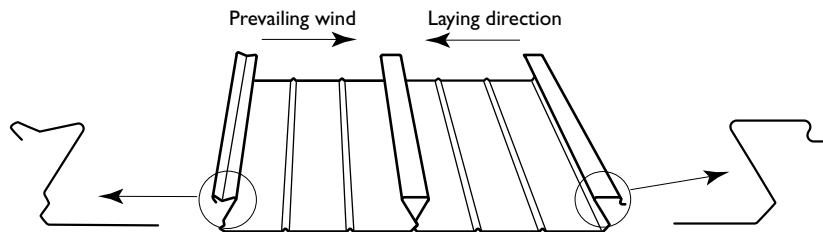

Figure 2:
Sequence of laying sheets

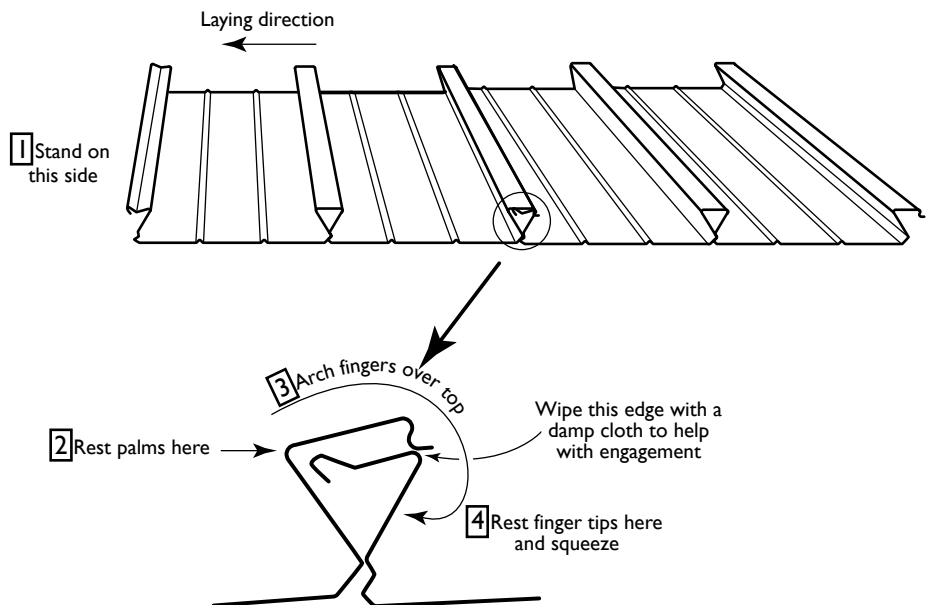

Figure 3:
Engaging the ribs

previous page).

- Fix the sheet at the receiver channel end (Figure on Page 3).

Place the next sheet with its rib on top of the rib of the first sheet, and with the house-end close to the receiver channel. Engage the ribs at the house end for the first 100 mm (Figure 3).

With a rubber mallet, tap the sheet into the receiver channel, ensuring the sheet beds firmly in the foam strip.

Complete engaging the ribs (Figure 3).

Check that the sheet fits snugly against the previous sheet by looking at the join between the sheets on the underside.

Fix the sheet as previously described. Repeat the process until all sheets are laid.

Fibreglass panels

FLATDEK II can be complemented with translucent fibreglass panels. The edges of these panels overlap the adjoining

FLATDEK II panels (Figure 4). Either side of a fibreglass panel there must be at least two FLATDEK panels before another fibreglass panel may be placed. Two fibreglass panels can not be laid next to each other. Slide fibreglass panels along the FLATDEK II into the receiver channel.

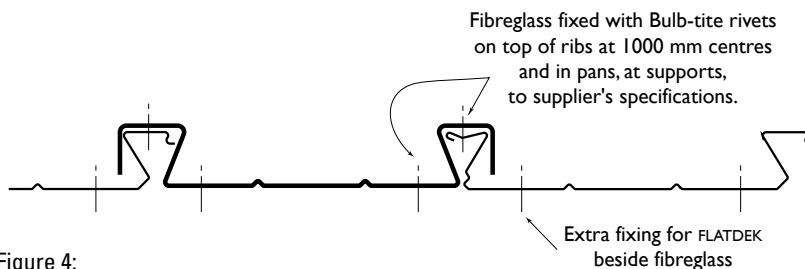

Figure 4:
Fixing of fibreglass panels

To ensure you get the most from your quality Lysaght products, we recommend the following:

Storage and handling

Keep the product dry and clear of the ground. If stacked or bundled product becomes wet, separate it, wipe it with a clean cloth and stack it to dry thoroughly.

Handle materials carefully to avoid damage: don't drag materials over rough surfaces or each other; carry tools, don't drag them; protect from swarf.

Cutting

For cutting thin metal on site, we recommend a circular saw with a metal-cutting blade because it produces fewer damaging hot metal particles and leaves less resultant burr than does a carborundum disc.

Disclaimer, warranties and limitation of liability

This publication is intended to be an aid for all trades and professionals involved with specifying and installing Lysaght products and not to be a substitute for professional judgement.

Terms and conditions of sale available at local BlueScope Lysaght sales offices.

Except to the extent to which liability may not lawfully be excluded or limited, BlueScope Steel Limited will not be under or incur any liability to you for any direct or indirect loss or damage (including, without limitation, consequential loss or damage such as loss of profit or anticipated profit, loss of use, damage to goodwill and loss due to delay) however caused (including, without limitation, breach of contract, negligence and/or breach of statute), which you may suffer or incur in connection with this publication.

© Copyright BlueScope Steel Limited July 14, 2007

Cut materials over the ground and not over other materials.

Sweep all metallic swarf and other debris from roof areas and gutters at the end of each day and at the completion of the installation. Failure to do so can lead to surface staining when the metal particles rust.

Sealants

Use neutral cure silicone sealants.

Adverse conditions

If this product is to be used in marine, severe industrial, or unusually corrosive environments, seek advice from our information line.

Metal & timber compatibility

Lead, copper, bare steel and green or some chemically-treated timber are not compatible with this product; thus don't allow any contact of the product with those materials, nor discharge of rainwater from them onto the product. Supporting members should be coated to avoid problems with underside condensation. If there are doubts about the compatibility of other products being used, ask for advice from our information line.

Pipe penetration

Flashing round small pipe penetrations is fairly simple using flanged sleeves or proprietary EPDM sleeves. Be careful to insulate incompatible materials.

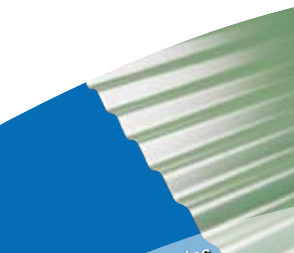

Information, brochures and your local distributor **1800 641 417**

Please check the latest information which is always available at www.lysaght.com

LYSAGHT, FLATDEK, COLORBOND and ZINCALUME are registered trademarks of BlueScope Steel Limited, ABN 16 000 011 058. The LYSAGHT® range of products is exclusively made by BlueScope Steel Limited trading as BlueScope Lysaght. Bulb-tite is a trademark of ITW Buildex. Printed by BMP 2M0907

