

Longline[®] 305

Steel roof cladding
with long, clean lines

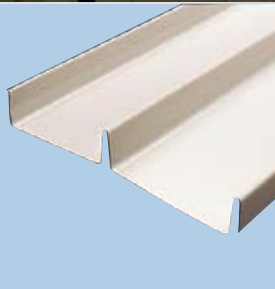
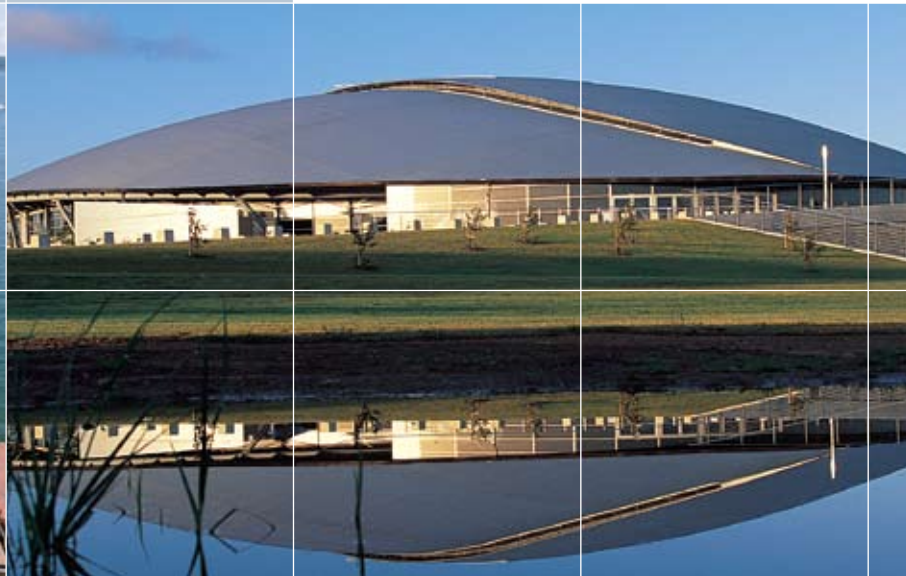

- Strong, durable, versatile cladding with narrow ribs and smooth pans
- Available in long lengths enabling ridge-to-gutter spans without end laps
- Available in 3 styles: plain (flat pans), fluted (small creases in the centre of the pan), and tapered (pan-width reduced by up to 50% of normal width at one end)
- Simple, low cost fixing that's fast, economical and effective

YSAGHT

Lysaght Longline 305

Steel roof cladding with long, clean lines

LONGLINE 305 is a concealed fixed roof cladding with bold ribs and wide pans. It is ideal for medium to large commercial and industrial installations.

The unique locking system fixes the cladding to the clip so no fasteners pass through the roofing. Concealed fixing means there are no penetrations so weathertightness is maximised.

LONGLINE's unique ability (among LYSAGHT claddings) to be tapered allows curved and rounded roof shapes to be clad with ribs radiating from a central point. Stylish indeed!

There are a wide range of COLORBOND® steel colours to choose from, as well as COLORBOND ULTRA® steel for more corrosive environments.

With over 150 years in steel roofing products, choosing LYSAGHT means you can be confident LYSAGHT LONGLINE 305 will perform year after year. Our BlueScope warranty is your assurance of that.

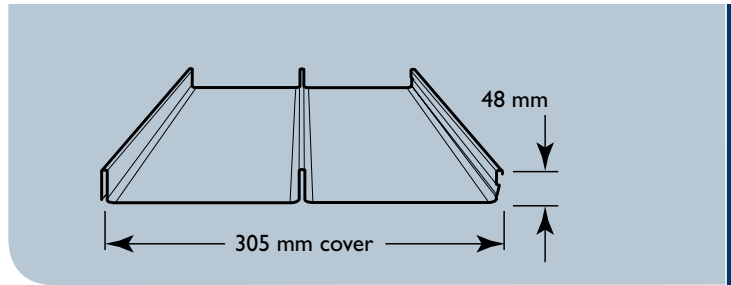

Masses

BMT	kg/m	kg/m ² *	m ² /t*
0.70 ZINCALUME	2.96	9.7	103
0.70 COLORBOND	2.99	9.81	102

* For plain flat pans.

Material specifications

LONGLINE 305 is made from ZINCALUME® aluminium/zinc alloy-coated steel complying with AS 1397 – 2001 G300, AZ150 (300 MPa minimum yield stress, 150 g/m² minimum coating mass).

The base metal thickness is 0.70mm.

The COLORBOND® prepainted steel complies with AS/NZS 2728:1997.

Lengths

Sheets are supplied custom cut.

Tolerances

Length: + 0mm, – 15mm

Width:

- standard & fluted: + 4mm, – 4mm
- tapered: + 5mm, – 5mm

Fasteners

	Fixing to steel up to 0.75 mm BMT	Fixing to steel >0.75 to 3 mm BMT	Fixing to timber
Concealed fixed	Self drilling self tapping screws with wafer-head 12-12x25 (M5.5-12x25)	Self drilling self tapping screws with wafer-head	Self drilling screws with wafer head SOFTWOOD: 10-12x35 (M4.8-12x35) HARDWOOD: 10-12x25 (M4.8-12x25) OR Spiral-threaded steel nails SOFTWOOD: 3.75 dia. x 60 HARDWOOD: 3.75 dia. x 40

Sheet coverage

Width of roof (m)	3	4	5	6	7	8	9	10	11	12	13	14	15	16	17	18	19	20	30	40	50
Number of sheets	10	14	17	20	23	27	30	33	37	40	43	46	50	53	56	60	63	66	99	132	164

Maximum Support Spacings (mm)

Type of span	BMT (mm) 0.70
Roofs	
Single span	1800
End span	2000
Internal span	2500
Unstiffened eaves overhang	150
Stiffened eaves overhang	450
Walls	
End span	2700
Internal Span	2700
Overhang	450

- For roofs: the data are based on foot-traffic
- For walls: the data are based on pressures (see wind pressure table)
- Supports must be not less than 1 mm BMT

Walking on roofs

Generally, keep your weight evenly distributed over the soles of your feet to avoid concentrating your weight on either heels or toes. Always wear smooth soft-soled shoes; avoid ribbed soles that pick up and hold small stones, swarf and other objects.

Whatever direction you walk, always walk in the pans. When walking across the width of the roof, walk over, or close to, the roof supports.

Maximum support spacings

The maximum recommended support spacings are based on testing in accordance with AS1562.1-1992, AS4040.0-1992 and AS4040.1-1992.

Roof spans consider both resistance to wind pressure and light roof traffic (traffic arising from incidental maintenance).

Wall spans consider resistance to wind pressure only.

The pressure considered is based on buildings up to 10m high in Region B, Terrain Category 3, $M_s=0.85$, $M_i=1.0$, $M_t=1.0$ with the following assumptions made:

Roofs:

$C_{pi}=+0.20$, $C_{pe}=-0.90$, $K_t=2.0$ for single and end spans, $K_t=1.5$ for internal spans

Walls:

$C_{pi}=0.20$, $C_{pe}=-0.65$, $K_t=2.0$ for single and end spans, $K_t=1.5$ for internal spans

These spacings may vary by serviceability and strength limit states for particular projects.

Fastening sheets to supports

LONGLINE 305 is concealed-fixed to timber or steel supports. This means that clips are screwed or nailed to the supports, and no fastening passes through the sheeting.

When LONGLINE 305 is fixed vertically, a fastener is fixed through each sheet, under the flashing or capping at the top of the sheet, to prevent the sheet sliding downward in the clips.

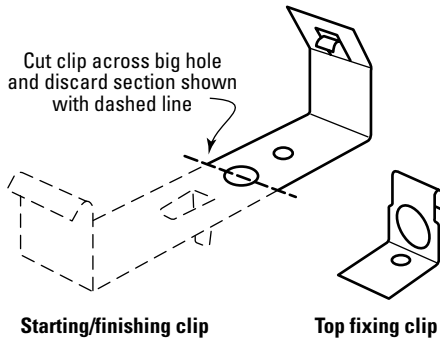

Maximum roof lengths for drainage measured from ridge to gutter (m)

Penetration will alter the flow of water on a roof. For assistance in design of roofs with penetrations, please seek advice from our information line.

Peak rainfall intensity mm/hr	Roof slope					
	1°	2°	3°	5°	7.5°	10°
100	219	273	320	398	475	546
150	146	182	213	265	317	364
200	110	136	160	199	237	273
250	88	109	128	159	190	218
300	73	91	107	133	158	182
400	55	68	80	100	119	136
500	44	55	64	80	95	109

LONGLINE 305®: Limit State wind pressure capacities (kPa)

Span type		Span (mm)						
		900	1200	1500	1800	2100	2400	2700
Base Metal Thickness 0.70 mm								
SINGLE	Serviceability	2.60	2.10	1.70	1.35	1.10	0.95	0.80
	Strength*	3.60	3.25	2.85	2.70	2.40	2.20	1.95
END	Serviceability	1.45	1.45	1.40	1.35	1.30	1.25	1.15
	Strength*	4.20	3.80	3.45	3.15	2.75	2.45	2.25
INTERNAL	Serviceability	2.05	1.90	1.80	1.65	1.55	1.45	1.30
	Strength*	5.20	4.90	4.55	4.15	3.65	3.05	2.50

Supports must be greater than 1.00 mm BMT

* A capacity reduction factor of $\phi = 0.9$ has been applied to strength capacities.

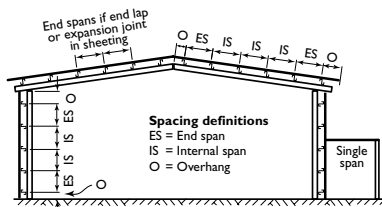

Limit states wind pressures

The wind pressure capacities are based on tests conducted at BlueScope Lysaght's NATA registered testing laboratory. Testing was conducted in accordance with AS 1562.1—1992 Design and Installation of Sheet Roof and Wall Cladding—Metal, and AS 4040.2—1992 Resistance to Wind Pressure for Non-cyclonic Regions.

The pressure capacities for serviceability are based on a deflection limit of $(\text{span}/120) + (\text{maximum fastener pitch}/30)$.

The pressure capacities for strength have been determined by testing the cladding to failure (ultimate capacity).

These pressures are applicable when the cladding is fixed to a minimum of 1.0mm, G550 steel.

For material less than 1.0mm thick, seek advice from our information line.

Adverse conditions

If this product is to be used in marine, severe industrial, or unusually corrosive environments, ask for advice from our information line.

Metal & timber compatibility

Lead, copper, free carbon, bare steel and green or some chemically-treated timber are not compatible with this product. Don't allow any contact of the product with those materials, nor discharge of rainwater from them onto the product. Supporting members should be coated to avoid problems with underside condensation. If there are doubts about the compatibility of other products being used, ask for advice from our information line.

Maintenance

Optimum product life will be achieved if all external walls are washed regularly.

Areas not cleaned by natural rainfall (such as the tops of walls sheltered by eaves) should be washed down every six months.

Safety, storage and handling

Handling Safety - LYSAGHT product may be sharp and heavy.

It is recommended that heavy-duty cut resistant gloves and appropriate manual handling techniques or a lifting plan be used when handling material.

Keep the product dry and clear of the ground. If stacked or bundled product becomes wet, separate it, wipe it with a clean cloth to dry thoroughly.

Handle materials carefully to avoid damage: don't drag materials over rough surfaces or each other; don't drag tools over material; protect from swarf.

Cutting

For cutting thin metal on site, we recommend a circular saw with a metal-cutting blade because it produces fewer damaging hot metal particles and leaves less resultant burr than a carborundum disc.

Cut materials over the ground and not over other materials.

Sweep all metallic swarf and other debris from roof areas and gutters at the end of each day and at the completion of the installation. Failure to do so can lead to surface staining when the metal particles rust.

Sealed joints

For sealed joints use screws or rivets and neutral-cure silicone sealant branded as suitable for use with galvanised or ZINCALUME® steel.

Non-cyclonic areas

The information in this brochure is suitable for use only in areas where a tropical cyclone is unlikely to occur as defined in AS 1170.2—2002.

For information on the use of LYSAGHT products in cyclonic conditions, refer to the Design Capacities for Cyclonic Areas brochure (formerly Cyclonic Area Design Manual) which is available on our website: www.lysaght.com. or by ringing Steel Direct on 1800 641 417.

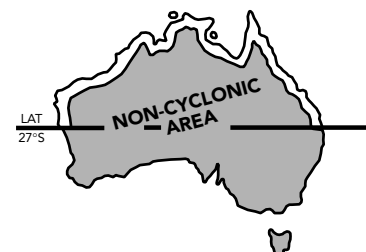

Installation

Preparation

Before starting, check that the supports on which your sheeting will rest are in the same plane; that the pitch and overhangs conform to the minimum specifications.

Orient sheets before lifting

Consider which end of the building is best to start from. So that side laps are protected, we recommend that you start laying sheets from the end of the building that will be in the lee of the worst anticipated or prevailing weather.

It is much easier and safer to turn sheets on the ground than up on the roof. Before lifting sheets on to the roof, check that they are the correct way up and the overlapping side is towards the edge of the roof from which installation will start.

Place bundles of sheets over or near firm supports, not at mid span of roof members.

Prepare clips

Cut all starting/finishing clips and discard the unwanted pieces.

Fix the first row of clips

With particular care, determine the location of the first sheet and mark the edge of the sheet on the purlins.

Fix the first clip on the purlin. Using a string line (or the first sheet as a straight edge) fix the other starting clips for the first sheet.

Place the first sheet

1. Locate the first sheet over the fixed clips (Figure 1).
2. Using a measurement from the gutter-end of the sheet to the fascia or purlin, position the sheet so that it overhangs the desired amount into the gutter.

When setting the first sheet, remember that it is important you keep the gutter-end of all sheets at a constant distance from the edge of the gutter or fascia.

3. Bend the tab of all clips over the rib (Figure 2).

Fix the next (and subsequent) clips and sheets

1. Using the rib closing tool, flatten the rib of the first (previous) sheet at each purlin where the top fixing clips will fit (Figure 3).
2. Place top fixing clips over each flattened rib and fix to the purlins (Figure 4). With a felt-tipped pen, make a small mark in the pan to enable you to locate the clips in the later locking operation with the button punch (Figure 5).
3. Place the next sheet over the edge of the preceding sheet (Figure 4).

Accurately position the sheet so that it overhangs the desired amount into the gutter. It is important that you keep the gutter-end of all sheets at a constant distance from the edge of the gutter or fascia.

4. Fully engage the sheet with the clips, using foot pressure on the ribs over each clip. You can do this by walking along the full length of the sheet with one foot in the tray next to the overlapping rib and the other foot applying pressure to the top of the interlocking ribs at regular intervals.

For walling applications use a rubber mallet instead of the weight on your feet.

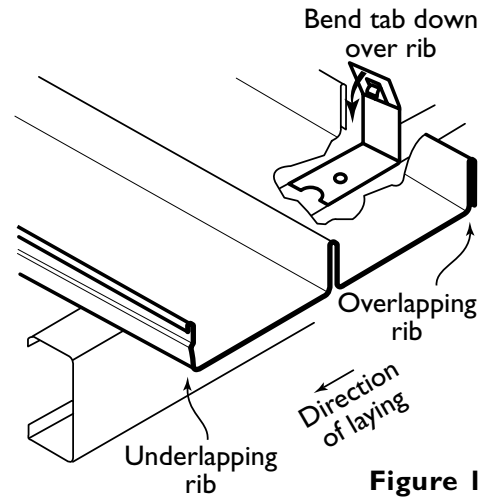

Figure 1

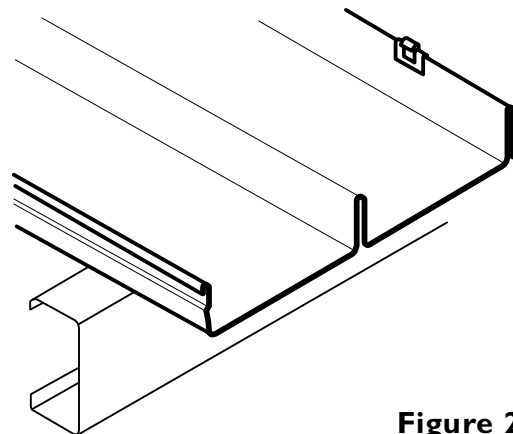

Figure 2

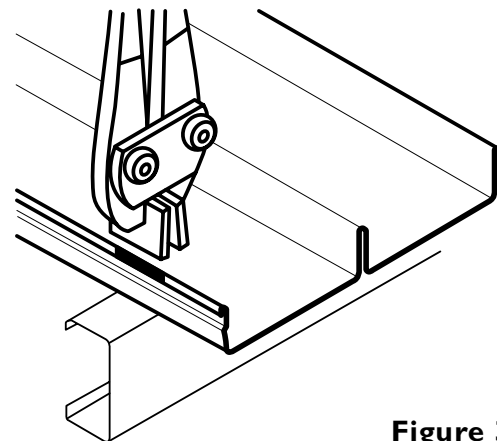

Figure 3

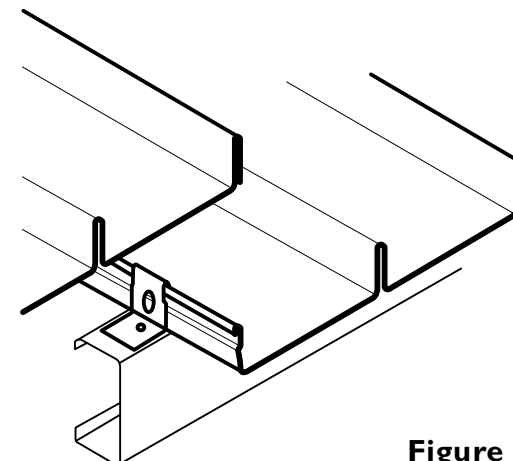

Figure 4

Check alignment periodically

Check that sheets are still parallel with the first sheet.

Place the last sheet

Assess how the last sheet will fit in relation to the fascia.

Fix a cut starting/finishing clip to the purlins.

Place the last sheet over the starting/finishing clips, and bend the tab of all clips over the rib.

Lock all ribs

All lapped ribs must be locked along their length, by button-punching at no greater than 900mm centres (Figure 5).

You must button-punch through the hole in each top fixing clip – you locate the clip with the pen mark made previously. When operating the punching tool, stand on the pan of the overlapping sheet to ensure that the sheets are fully engaged.

Ends of sheets

Wind can drive water uphill under the flashings or cappings. Also, at the low end of a roof, wind or capillary action can cause water to run back up the underside of sheeting. To minimise these problems, turn the pans up at the top of sheets, and turn them down at the bottom. A tool is available for these jobs (Figure 6).

Turning-up

Flush turn-ups are usually used on longline 305. Cut off a portion of the female rib for at least 50mm. For a flush turn-up, you also need to cut the crown of the centre rib for at least 50mm.

Holding the end of the tool against the end of the sheet, pull the handle up 90°. If turning-up flush, fold the protruding ears flush against the turn-up tool with a rubber mallet (Figure 7).

Turning-down

All roofing on slopes below 1 in 5 (10°) must be turned-down (also called lipped).

Turning-down is usually done after the sheeting is fixed on the roof, provided there is no obstruction to the operation of the turn-down tool.

- Push the turn-down tool over the end of the tray, as far as it will go.
- Hold the tool hard against the end of the tray and push the handle to form a turn-down about 20 degrees (Figure 8).

End-lapping

Underlapping ribs have to be slightly squashed at the lap to allow them to nest – an end-lap tool is available for the job.

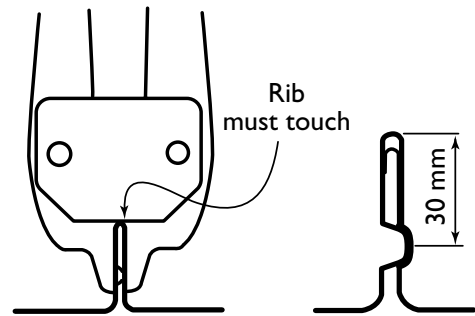

Figure 5

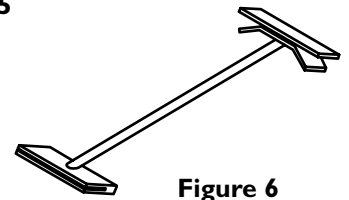

Figure 6

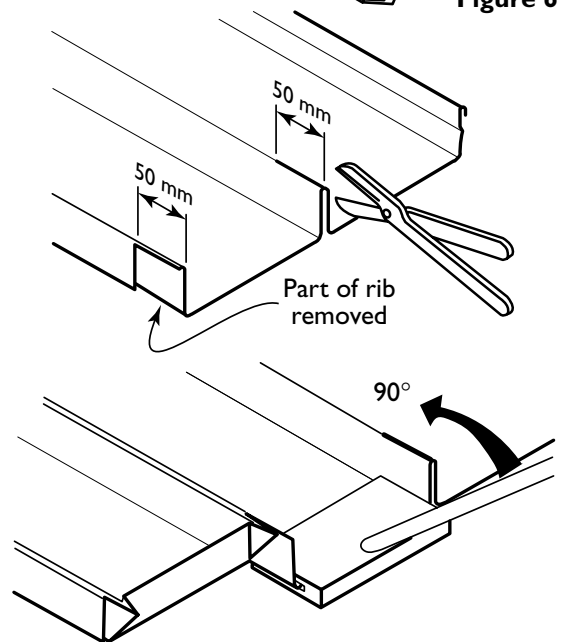

Figure 7

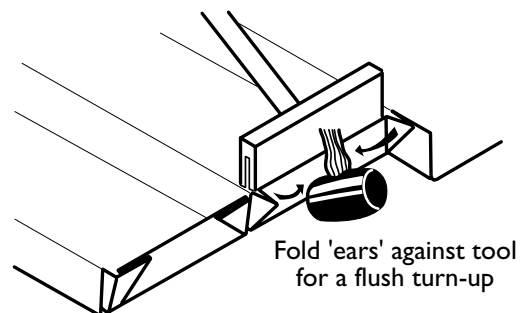

Figure 8



Versatile variations of Longline 305



We can taper LONGLINE 305 in its width to produce a sheet that lends itself to a wide range of roof designs. The taper can be left hand or right hand.

You should get our advice for long spans or high loadings.

New COLORBOND steel with Thermatech™ technology

The next generation COLORBOND® steel incorporates Thermatech™ technology, which provides a new level of thermal protection by absorbing less heat. Average reduction in solar absorbance across all colours is 5%.

Now 14 of the 20 COLORBOND steel colours are 'medium to light' under the BASIX colour classification, which means reflective foil at the roof is not required. It also means a drop of R0.5 for roof insulation.

Disclaimer, warranties and limitation of liability

This publication is intended to be an aid for all trades and professionals involved with specifying and installing LYSAGHT products and not to be a substitute for professional judgement.

Terms and conditions of sale available at local BlueScope Lysaght sales offices.

Except to the extent to which liability may not lawfully be excluded or limited, BlueScope Steel Limited will not be under or incur any liability to you for any direct or indirect loss or damage (including, without limitation, consequential loss or damage such as loss of profit or anticipated profit, loss of use, damage to goodwill and loss due to delay) however caused (including, without limitation, breach of contract, negligence and/or breach of statute), which you may suffer or incur in connection with this publication.

© Copyright BlueScope Steel Limited August 2008

www.lysaght.com

Information, brochures and your local distributor

1800 641 417

Please check the latest information which is always available at www.lysaght.com

LYSAGHT, LONGLINE 305, THERMATECH™, COLORBOND and ZINCALUME are registered trademarks of BlueScope Steel Limited, ABN 16 000 011 058. The LYSAGHT® range of products is exclusively made by BlueScope Steel Limited trading as BlueScope Lysaght. Printed by BMP 2M0908

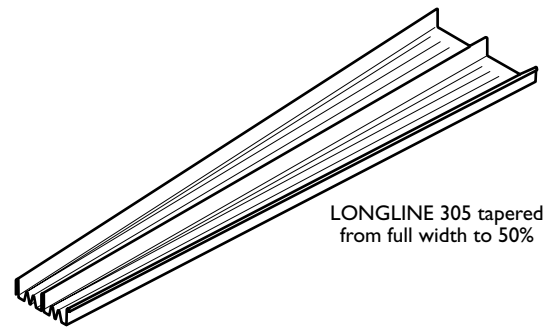

LONGLINE 305 tapered from full width to 50%



Standard width (cover 305 mm)



Fluted (cover 300 mm)

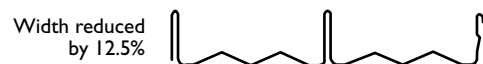

Width reduced by 12.5%



Width reduced by 25%

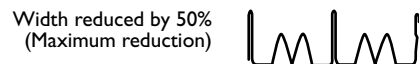

Width reduced by 50% (Maximum reduction)

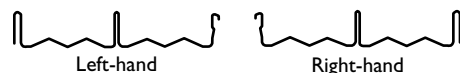

Left-hand

Right-hand



**BLUESCOPE
LYSAGHT**



9 320075 056148