

# Lysaght Mini Orb<sup>®</sup>

Subtly corrugated  
steel wall cladding



- Traditional style in an elegant profile, LYSAGHT MINI ORB<sup>®</sup> is suitable for use in interior or exterior applications, on straight or curved surfaces.
- MINI ORB can be installed with the corrugations running vertically or horizontally.
- MINI ORB can be laid flat, pre-curved, or spring-curved for increased versatility.

**LYSAGHT**

# LYSAGHT MINI ORB®

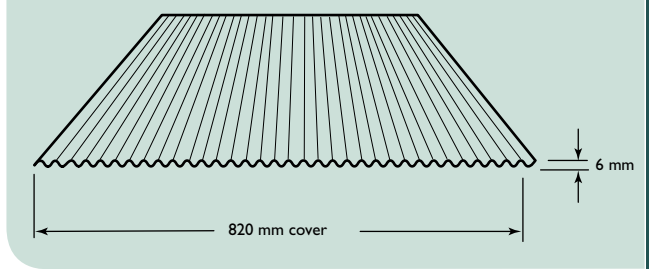

## Design freedom

Traditional style in an elegant profile, LYSAGHT MINI ORB® steel wall cladding is a sophisticated product from BlueScope Lysaght which is suitable for use in interior or exterior applications, on straight or curved surfaces.

MINI ORB's subtle profile is a perfect complement to other LYSAGHT claddings to provide a 'contrasting' surface as an accent feature.

MINI ORB is primarily used for decorative finishes on walls, ceilings and soffit linings; feature walls and partitions; and screens and small awnings not subject to any foot traffic. It is a product that gives you freedom in design allowing your creativity to blend perfectly with the practical.

However, MINI ORB's attractive profile makes it suitable for a myriad of original design applications, such as furniture; fencing and gates; awnings and shop fittings; and interior ceilings in both the industrial and domestic markets.

MINI ORB's long lengths allow design freedom, and eliminates unattractive end laps.

## Masses

	BMT (mm)	kg/m	kg/m <sup>2</sup>	m <sup>2</sup> /t
ZINCALUME	0.42	3.26	3.97	251
	0.48	3.70	4.51	221
COLORBOND	0.42	3.32	4.04	247
	0.48	3.76	4.58	218

## Material specifications

- MINI ORB is made from ZINCALUME® aluminium/zinc alloy-coated steel complying with AS 1397—2001 G550, AZ150 (550 MPa minimum yield stress, 150 g/m<sup>2</sup> minimum coating mass). Base metal thicknesses (BMT) available are 0.42 and 0.48 mm. (NSW & Qld 0.48 metallic only available, 0.48 not available in SA)
- The COLORBOND® prepainted steel complies with AS/NZS 2728:1997.

## Lengths

Sheets are supplied custom cut.

## Tolerances

Length: + 0 mm, - 15 mm

Width: + 2 mm, - 2 mm

## Colours

MINI ORB is available in an attractive range of COLORBOND® steel pre-painted colours and in unpainted ZINCALUME® and stainless steel. Check with your local distributors for the colour range available in your area. The standard pre-painted finish is COLORBOND® steel, but COLORBOND® Metallic finish provides superior aesthetic qualities, and COLORBOND® Ultra finish is intended for severe coastal or industrial environments.

Direction of laying →

← Prevailing weather

Valley: 6 fixings (every 6th valley)

Valley: 11 fixings (every 3rd valley)

Refer to wind pressure capacity table to select quantity of fasteners.

## Sheet coverage

Width of wall (m)	3	4	5	6	7	8	9	10	11	12	13	14	15	16	17	18	19	20	30	40	50
Number of sheets	4	5	7	8	9	10	11	13	14	15	16	18	19	20	21	22	24	25	37	49	61

## Maximum Support Spacings

The maximum recommended support spacings are based on testing in accordance with AS1562.1-1992 and AS4040.2-1992.

Wall spans consider resistance to wind pressure only.

The pressure considered is based on buildings up to 10m high in Region B, Terrain Category 3,  $M_s=0.85$ ,  $M_f=1.0$ ,  $M_t=1.0$  with the following assumptions made:

## Walls:

$C_{pi}=+0.20$ ,  $C_{pe}=-0.65$ ,  $K_f=2.0$  for single spans,  $K_f=1.5$  for internal spans.

These spacings may vary by serviceability and strength limit states for particular projects.

## Maximum support spacings for walls

Type of span	BMT (mm)	
	0.42	0.48
Single span	1200	1500
End span	1500	1500
Internal span	1500	1500
Overhang	100	125

- For walls: the data are based on pressures (see wind pressures table).
- Table data are based on supports of 1mm BMT.

## Curving information

MINI ORB may be spring curved down to 1500mm radius. It is suitable for pre-curving—the minimum radius of curve is 150mm, and the minimum straight length after a curve is 50mm. Some possible profiles are shown below.

## Fastening sheets to supports

MINI ORB is valley fixed to timber or steel supports. Place fasteners no less than 15mm from ends of sheets.

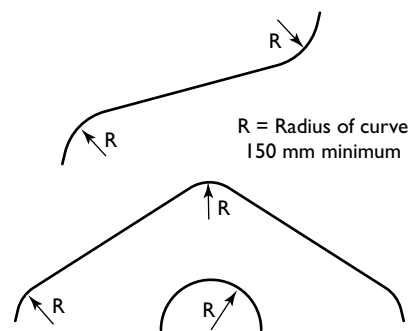

## Fasteners

	Fixing to steel up to 3mm BMT	Fixing to timber
Valley fixing	Ripple Tek® screws 10-16 x 20	Ripple Tek screws SOFTWOOD and HARDWOOD 10-16 x 30
Side-lap & accessories	As above OR sealed aluminium blind rivets 3.2 mm diameter	

## Mini Orb: Limit state wind pressure capacities (kPa)

Span type	Limit state	Fasteners per sheet per support	0.42 mm base metal thickness					0.48 mm base metal thickness				
			Span (mm)					Span (mm)				
			450	600	900	1200	1500	450	600	900	1200	1500
SINGLE	Serviceability	11	6.30	3.93	0.96	0.19	7.14	4.72	1.58	0.55	0.33	
	Strength*	11	12.00	12.00	12.00	10.40	12.00	12.00	12.00	11.40	8.80	
	Serviceability	6	6.20	3.99	1.17	0.35	7.00	4.71	1.72	0.69	0.40	
	Strength*	6	11.70	10.15	7.65	5.70	12.00	12.00	8.25	6.10	4.85	
END	Serviceability	11	6.12	4.33	1.89	0.87	0.40	7.60	5.22	2.03	0.82	0.35
	Strength*	11	12.00	12.00	9.35	7.20	5.75	12.00	12.00	10.95	8.50	7.20
	Serviceability	6	6.50	4.69	2.17	1.00	0.34	7.50	5.35	2.38	1.07	0.39
	Strength*	6	8.80	7.30	5.10	3.95	3.15	10.95	8.95	6.10	4.75	3.95
INTERNAL	Serviceability	11	7.20	5.01	2.06	0.88	0.37	8.20	5.97	2.89	1.53	0.82
	Strength*	11	12.00	12.00	10.70	8.10	6.35	12.00	12.00	12.00	9.30	7.55
	Serviceability	6	7.00	5.23	2.67	1.33	0.46	8.00	5.89	2.94	1.57	0.80
	Strength*	6	11.70	9.25	5.85	4.30	3.50	12.00	10.90	6.80	5.10	4.20

\* A capacity reduction factor of  $\phi = 0.9$  has been applied to strength capacities  
Supports must be not less than 1 mm BMT.

## Limit states wind pressures

LYSAGHT MINI ORB offers the full benefits of the latest methods for modelling wind pressures. The Wind Pressure Capacity table is determined by full scale tests conducted at BlueScope Lysaght's NATA-registered testing laboratory, using the direct pressure-testing rig.

Testing was conducted in accordance with AS 1562.1:1992 Design and Installation of Sheet Roof and Wall Cladding—Metal, and AS 4040.2:1992 Resistance to Wind Pressures for Non-cyclonic Regions.

The pressure capacities for serviceability are based on a deflection limit of  $(\text{span}/120) + (\text{maximum fastener pitch}/30)$ .

The pressure capacities for strength have been determined by testing the cladding to failure (ultimate capacity). These pressures are applicable when the cladding is fixed to a minimum of 1.0mm, G550 steel.

For material less than 1.0mm thick, seek advice from our information line.

## Adverse conditions

If this product is to be used in marine, severe industrial, or unusually corrosive environments, ask for advice from our information line.

## Metal & timber compatibility

Lead, copper, bare steel and green or some chemically-treated timbers are not compatible with this product; thus don't allow any contact of the product with those materials, nor discharge of rainwater from them onto the product.

If there are doubts about the compatibility of products being used, ask for advice from our information line.

## Maintenance

Optimum product life will be achieved if all external surfaces are washed regularly. Areas not cleaned by natural rainfall (such as the tops of walls sheltered by eaves) should be washed down every six months.

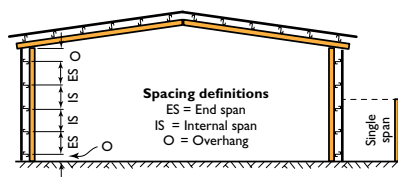

## Storage and handling

Keep the product dry and clear of the ground. If stacked or bundled product becomes wet, separate it, wipe it with a clean cloth and stack it to dry thoroughly.

Handle materials carefully to avoid damage: don't drag materials over rough surfaces or each other; carry tools, don't drag them; protect from swarf.

## Cutting

For cutting thin metal on site, we recommend a circular saw with a metal-cutting blade because it produces fewer damaging hot metal particles and leaves less resultant burr than a carborundum disc.

Cut materials over the ground and not over other materials.

Sweep all metallic swarf and other debris from roof areas and gutters at the end of each day and at the completion of the installation. Failure to do so can lead to surface staining when the metal particles rust.

## Sealed joints

For sealed joints use screws or rivets and neutral-cure silicone sealant branded as suitable for use with galvanised or ZINCALUME® steel.

## Non-cyclonic areas

The information in this brochure is suitable for use only in areas where a tropical cyclone is unlikely to occur as defined in AS 1170.2:2002.

For information on the use of LYSAGHT products in cyclonic conditions, refer to the Cyclonic Area Design Manual which is available by ringing Steel Direct on 1800 641 417 or on our website: [www.lysaght.com](http://www.lysaght.com).



# Installation

You will always get a better appearance by taking a little extra care to ensure an evenly finished job, with uniform light reflection. Make sure that the supporting structure is as rigid and as flat as possible.

The tables in this brochure are based on sheets being overlapped by 1.5 corrugations.

Always use at least two people to install MINI ORB.

## Support spacings

For best aesthetic results on all installations, limit support spacings to 900 mm maximum.

For walls, follow the table Maximum Support Spacings for walls (Page 2).

## Ceiling installation

Start fixing near the centre of a sheet, on one edge, and work outwards towards the ends of the sheet.

## Wall installation

MINI ORB can be installed with the corrugations running vertically or horizontally.

## Trimming

MINI ORB trims vary in availability and dimensions from region to region. For local availability, contact your BlueScope Lysaght sales representative or refer to your State's published Price List.

## Trims

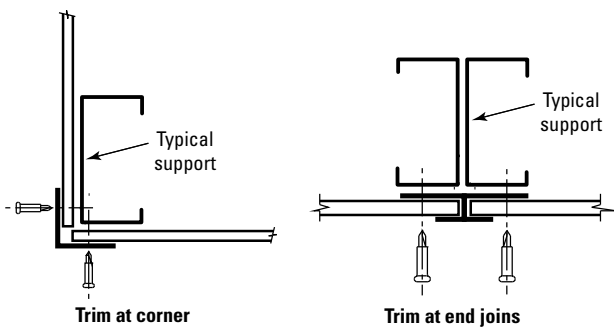

## Horizontal corrugations

Decide how the sheet width will best cover the height of the wall, giving each overlap the same number of corrugations. Overlaps of more than two or three corrugations may detract from the final look of the job.

Start fixing near the centre of a sheet, on one edge, and work outwards towards the ends of the sheet. Place successive rows of fasteners parallel with the first row, working similarly from the centre.

If the sheet is long (about 3000mm or longer), be very careful that the sheet remains straight, along its top and bottom edges.

## Vertical corrugations

Follow the same general procedure as that described for horizontal corrugations. Take care when you place each row of screws, that the corrugations are not flattened, thus forcing the sheet to become wider.

## End laps

For aesthetic reasons, end laps are not recommended (see Trimming).

## Fastening

For ceilings, fasteners may be placed along the sheet at up to 1200mm centres.

MINI ORB should be fixed to all intermediate battens or studs to prevent noise if the sheet flexes with pressure fluctuations in the building.

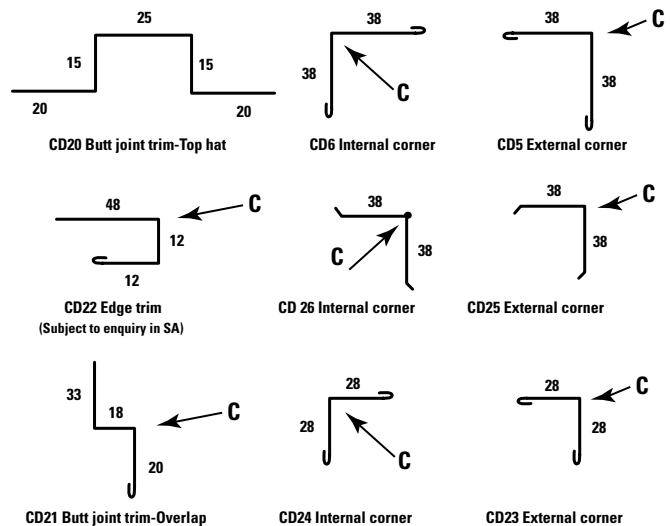

C= coloured face

## Disclaimer, warranties and limitation of liability

This publication is intended to be an aid for all trades and professionals involved with specifying and installing Lysaght products and not to be a substitute for professional judgement.

Terms and conditions of sale available at local BlueScope Lysaght sales offices.

Except to the extent to which liability may not lawfully be excluded or limited, BlueScope Steel Limited will not be under or incur any liability to you for any direct or indirect loss or damage (including, without limitation, consequential loss or damage such as loss of profit or anticipated profit, loss of use, damage to goodwill and loss due to delay) however caused (including, without limitation, breach of contract, negligence and/or breach of statute), which you may suffer or incur in connection with this publication.

© Copyright BlueScope Steel Limited, March 31, 2009

[www.lysaght.com](http://www.lysaght.com)

Information, brochures and your local distributor

**1800 641 417**

Please check the latest information which is always available at [www.lysaght.com](http://www.lysaght.com)

LYSAGHT, MINI ORB, CUSTOM ORB, COLORBOND and ZINCALUME are registered trademarks of BlueScope Steel Limited, ABN 16 000 011 058. The LYSAGHT® range of products is exclusively made by BlueScope Steel Limited trading as BlueScope Lysaght. Printed by BMP1M0409

